

TURBODRIVE
400 H.C.
WATERJET



ADVANCED HIGHLY EFFICIENT MARINE PROPULSION SYSTEM

CASTOLDI JET

THE CASTOLDI **TURBODRIVE 400 H.C.** IS NOT ONLY THE RESULT OF ALL THE EXPERIENCE GAINED SINCE 1962 THROUGH THE SUPPLY AND INSTALLATION OF MORE THAN 40.000 WATERJETS WORLD-WIDE. IT IS THE OUTCOME OF SPECIFIC INTENSIVE RESEARCH AND DEVELOPMENT ACTIVITIES AIMED AT FURTHER IMPROVING THE HIGH EFFICIENCY OF CASTOLDI WATERJETS. THIS GOAL WAS PURSUED THROUGH SELF-PROPULSION TRIALS (USING 24 TRUE-SCALE MODELS) PERFORMED BY MEANS OF AN INSTRUMENTED LABORATORY BOAT.

AS A RESULT, THE CASTOLDI **TURBODRIVE 400 H.C.**, IS THEREFORE AN ADVANCED TOP-PERFORMANCE HIGH SPEED WATERJET. FITTED WITH A SINGLE STAGE AXIAL FLOW IMPELLER, IT CAN BE DRIVEN BY A GASOLINE OR A DIESEL ENGINE, WITH A MAXIMUM OUTPUT OF 882 KW DEPENDING ON BOAT SPEED.

THE **TURBODRIVE 400 H.C.** IS A MASS-PRODUCED UNIT IN HIGH-STRENGTH MARINE ALUMINUM ALLOY CASTINGS ALLOWING IT TO MEET THE GOAL OF BEING A LIGHT AND STRONG PROPULSION SYSTEM. IT IS PROTECTED BY THE MOST UP-TO-DATE AND SOPHISTICATED ANTI-CORROSION TREATMENTS.

THE IMPELLER, THE SHAFTS, THE GEAR WHEELS AND ALL OTHER METAL ITEMS NOT IN ALUMINUM ALLOY ARE MADE OF HIGH-GRADE STAINLESS STEEL, STEEL, TITANIUM AND BRONZE ALUMINUM ALLOY.

THE **TURBODRIVE 400 H.C.** IS EQUIPPED WITH EXCLUSIVE PARTICULARS WHICH MAKE THIS MODEL A COMPLETE, UNIQUE AND TRUE MARINE PROPULSION UNIT. THESE INCLUDE THE INTEGRATED MULTI-RATIO GEARBOX WHICH FINELY MATCHES THE POWER AND R.P.M. CHARACTERISTICS OF THE ENGINE TO THE WATERJET, THE HYDRAULIC MULTI-DISC DISCONNECTING CLUTCH FOR ENGAGING AND DISENGAGING THE UNIT, THE FLUSH MOUNTED MOVABLE GRID FOR PREVENTING THE ASPIRATION OF DEBRIS INTO THE WATERJET AND CLEANING THE INTAKE DUCT, JUST TO NAME A FEW.

IT IS ALSO EQUIPPED WITH A SPECIALLY DEVELOPED PACKAGED CONTROL SYSTEM AND OTHER EQUIPMENT WHICH ALLOW MAXIMIZATION OF ITS IMPRESSIVE INHERENT MANOEUVRING CAPABILITIES.

TURBODRIVE 400 H.C.



BENEFITS

PERFORMANCE

- The highest efficiency in the 25 to 60 knot speed range
- Much higher top speed versus fixed pitch propeller system, higher top speed versus pod-drives and competitor waterjets and consequent better fuel economy (from 25 knots and up)
- Fast acceleration
- No interference in multiple installations
- Waterjet power absorption is insensitive to boat speed meaning full thrust is maintained when boat drag changes

SAFETY

- Absence of open rotating blades
- Absence of any appendage under hull
- Unrivaled emergency crash stop capability
- Virtually invulnerable to floating debris and to unexpected boat grounding

PRACTICALITY

- Maximum endurance and protection from marine corrosion
- Ease of installation and alignment
- Operation in shallow waters and easy beaching
- Minimum service requirements
- Ease of maintenance
- Limited in-board room requirements
- Lower weight compared to any other propulsion system fitted with marine transmission
- Reduced magnetic signature
- More uniform engine loading allows for longer engine life

COMFORT

- Absence of vibration and reduced internal noise

MANOEUVRABILITY

- Outstanding maneuverability at all speeds
- Easier handling for docking (zero speed with 360° high thrust availability)
- In multiple installations, the vessel can even move sideways (no need of bow thrusters)

TECHNICAL SPECIFICATIONS

INPUT FLANGE: SUITS UP TO 8,86" (225 MM) DIAMETER DRIVE SHAFT FLANGE

IMPELLER TYPE: THREE BLADES, SINGLE STAGE, AXIAL FLOW

IMPELLER DIAMETER: 400 MM - AT THE INLET

INTEGRATED GEARBOX: WITH 21 GEAR WHEEL-RATIOS AVAILABLE

WATERJET IMPELLER DISCONNECTING SYSTEM: BUILT-IN MULTI-DISC HYDRAULIC CLUTCH, ELECTRICALLY OPERATED

UNIT DRY WEIGHT: 480 KG INCLUDING: GEARBOX, HYDRAULIC CLUTCH, WATER INTAKE, DUCT, ANODES, LEVERS

HYDRAULIC WEIGHT: 50 KG INCLUDING: OIL PUMP, HYDRAULIC ACTUATORS, BRACKETS, VALVES AND PIPES

VOLUME OF WATERJET OIL: 22 LT (GEARBOX AND HYDRAULICS)

VOLUME OF ENTERTAINED WATER: 114 LT

TRANSOM ANGLE: 90°

ROTATION: CLOCKWISE VIEWED ON INPUT SHAFT

INSPECTION HATCH: INBOARD

HYDRAULIC ACTUATORS: INBOARD, MOUNTED ON WATERJET INTEGRATED BRACKETS FOR REVERSING AND STEERING CONTROL

STATOR: WITH N. 5 BLADES

WATER PICK-UP FOR ENGINE COOLING: SUIT 2,5" GAS

HYDRAULIC: OIL PUMP DIRECTLY SPLINED TO THE INPUT SHAFT

REVERSING SYSTEM: SPECIAL TWIN-DUCT TYPE BUCKET. (75 % OF THE FORWARD STATIC THRUST), HYDRAULICALLY ACTUATED

STEERING SYSTEM: STEERING NOZZLE INTEGRATED IN A PROTECTIVE BOWL, HYDRAULICALLY ACTUATED

WATER INTAKE PROTECTION: DEBRIS SCREEN GRID WITH HYDRODINAMICALLY PROFILED MOVABLE BARS, HYDRAULICALLY ACTUATED

B.P.R.: ADDITIONAL WATER INTAKE FOR SLOW AND/OR HEAVY VESSELS. (OPTIONAL)

CLEAR-DUCT: WATERJET DUCT AND INTAKE CLEANING SYSTEM ASSURED THROUGH THE SYNCHRONIZED SIMULTANEOUS ELECTRICALLY CONTROLLED OPERATIONS OF IMPELLER ROTATION REVERSING AND THE DEBRIS SCREEN GRID OPENING. (OPTIONAL)

INPUT POWER: FOR PLANING BOATS UP TO 882 KW (1.200 mHP) INTERMITTENT DUTY; UP TO 736 KW (1.000 mHP) CONTINUOUS DUTY

FOR DISPLACEMENT BOATS: UP TO 272 KW (370 mHP)

MAIN PART MATERIALS

IMPELLER: DUPLEX STAINLESS STEEL

IMPELLER HOUSING: G.AI.SI.9 ALUMINUM ALLOY

IMPELLER HOUSING WEAR RING: TITANIUM

IMPELLER SHAFT: AQUAMET 17 STAINLESS STEEL

INPUT SHAFT: 39 NI.CR.MO. 3 HIGH GRADE STEEL

STATOR: G.AI.SI.7 ALUMINUM ALLOY

STEERING NOZZLE AND REVERSING BUCKET: G.AI.SI.7 ALUMINUM ALLOY

STEERING SHAFT: NITRONIC 50

REVERSING SHAFT: AISI 316 STAINLESS STEEL

WATERJET BODY: G.AI.SI.9 ALUMINUM ALLOY

GEAR WHEELS: SURFACE CARBO HARDENED HIGH GRADE 18 NI.CR.MO. 5 STEEL

THE WHOLE UNIT IS PROTECTED BY A HARD ANODIZING TREATMENT, PLATING ALL LIGHT-ALLOY COMPONENTS WITH 60 MICRONS THICKNESS OF ALUMINUM OXIDE (CERAMIC), THREE LAYERS OF SPECIAL PAINT AND CATHODIC PROTECTION BY ZINC ANODES

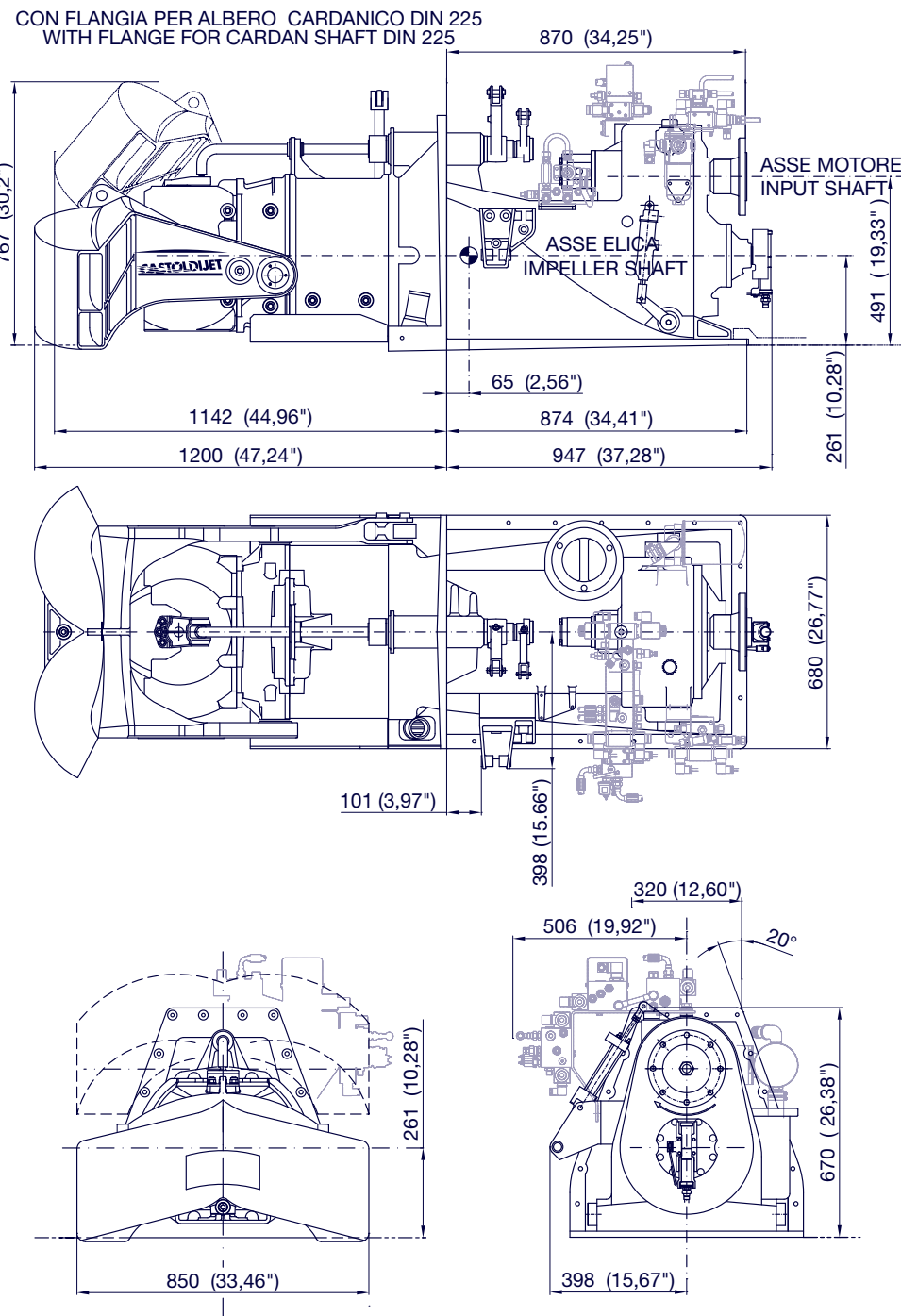



CASTOLDI

SINCE 1962 LEAPS AHEAD IN MARINE PRODUCTS

CASTOLDI JET

www.castoldijet.it